

-PowerBreaker-

SPD WIRING KIT - **PBSUWK** (SURGE PROTECTIVE DEVICE)

The PowerBreaker range of circuit protection devices are designed and tested for use with PowerBreaker Consumer Units.

These devices **MUST** be installed by a qualified electrician in accordance with the latest wiring regulations (BS7671).

+ Type 2

+ Kit Includes SPD (PBSPD) , 32A MCB (PBM32B), connection wires & labels

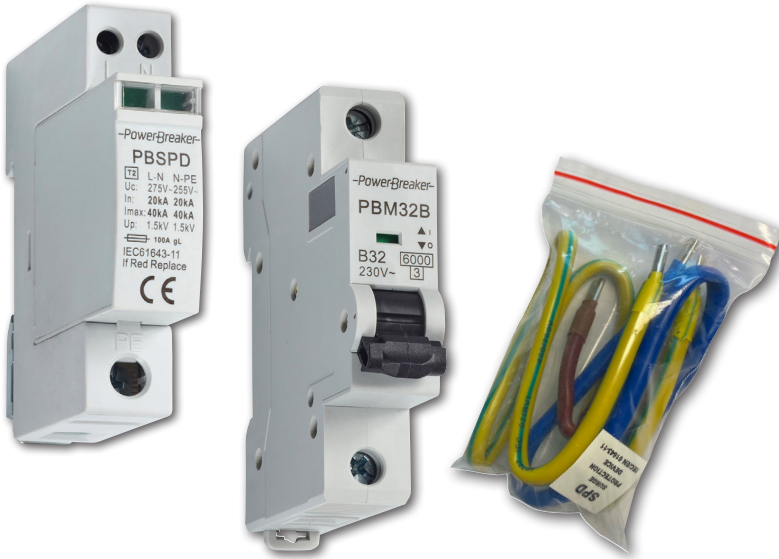

**Also available
Part No PBSML
Replacement SPD Module**



TECHNICAL DATA SHEET

	PBSPD	
Description	Type 2 SPD Supplied in SPD Kit Part No: PBSUWK	
Pack Quantity	1	
Barcode	5012739648700	
Test Class	Type II	
Terminal Connections	L - N	N - PE
Rated Working Voltage of Uo (v)	230V~50Hz	
Max. Discharge Current I_{max} 8/20µs	40kA	
Nominal Discharge Current In 8/20µs	20kA	
Max. Continuous Operation Voltage U_c	275V	255V
Voltage Protection Level U_p	1.5kV	
Short Circuit Current Rating I_{sc}cr	500A	
Protection Type	MOV	Gas Discharge Tube
Wiring Capacity	L/N 2.5mm ² , PE 6mm ²	
Number of Poles	2	
Protection Class	IP20	
Status Indicator	Green - Normal Red - Failure	
Mounting	35mm Din Rail	
Casing Material	Thermal Plastic UL94V-0	
Guarantee	3 Years	
Conforms To	EN 61643-11	

	PBM32B
Description	32A MCB
Rated Residual Current	32A
Number of Poles	1P (Single Pole)
Rated Voltage	230/240VAC
Rated Frequency	50/60Hz
Rated Short-Circuit Capacity	6kA
Tripping Characteristics	Type B
Index of Protection	IP20
Terminals	1 -25mm ²
Mechanical Endurance	10,000 times
Electrical Endurance	4,000 times
Ambient Temperature	- 25°C to +55°C
Storage Temperature	- 40°C to +70°C
Torque (Recommended minimum tightening)	2.0Nm
Din Rail Mounting	Yes
Guarantee	3 Years
Conforms To	BS EN 60898

-PowerBreaker-

SPD WIRING KIT - **PBSUWK** (SURGE PROTECTIVE DEVICE)

This SPD unit is a single module but has L (Live), N (Neutral) & PE (earth connections), it uses MOV across the Live & Neutral and a gas discharge tube across Earth & Neutral to dissipate any voltage spikes.

Line Drawing - PBSPD

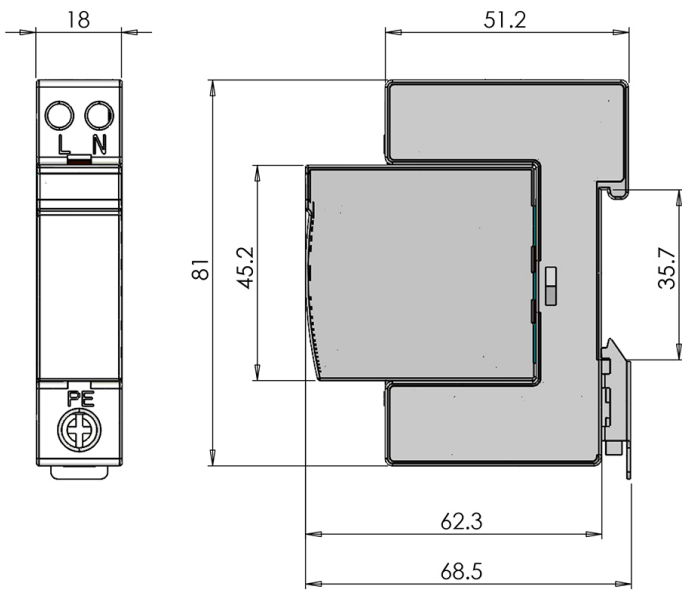

Circuit Diagram

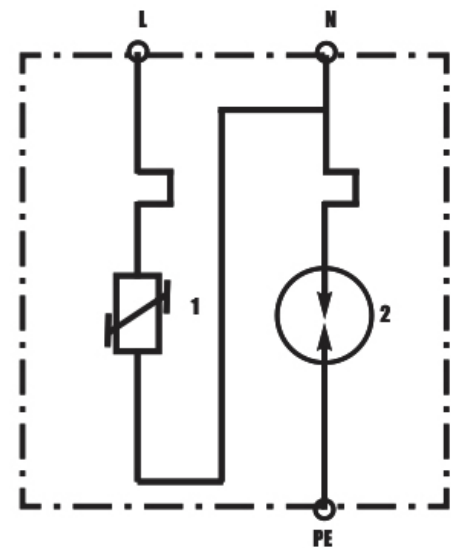

1 = MOV
2 = Gas discharge tube

Line Drawing - PBM32B

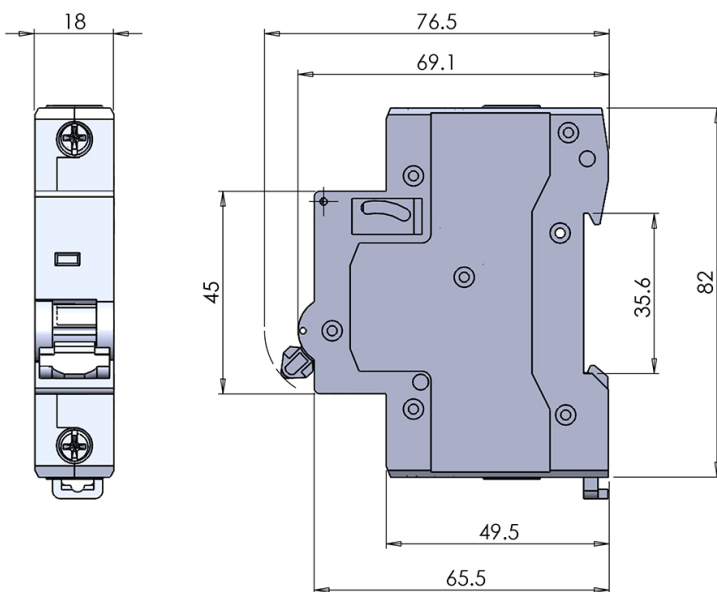

-PowerBreaker-

SPD WIRING KIT - PBSUWK (SURGE PROTECTIVE DEVICE)

SPD Wiring Diagram

